

# HOSELINE

## Overhead Environmental Cabinet

AC/DC OPERATION

LOW POWER CONSUMPTION

FITS IN OVERHEAD SPACE

ELECTRONIC TEMPERATURE CONTROL

LONG LIFE - BRUSHLESS DC COMPRESSOR

HEATS AND COOLS TO MAINTAIN TEMPERATURE



### DESCRIPTION

The Hoseline Overhead Environmental Cabinet was specifically designed to keep pharmaceuticals, samples, chemicals and other temperature critical substances safe from environmental extremes. The built-in computer controlled monitoring system maintains set point temperature to within  $\pm 2$  degrees. The Overhead Environmental Cabinet was designed to fit in the overhead storage space in most emergency vehicles. The unit features a user selectable temperature range of 35° to 80°F.

The control panel features a large, easy to read LED display of inside temperature. Simple pushbutton operation allows for easy setting of the desired set point temperature. The temperature can be displayed in either degrees Fahrenheit or Celsius. An alert indicator illuminates should the inside temperature exceed 5 degrees above or below the desired set point. Set point and operating mode data is stored in non-volatile memory allowing the control to automatically return to proper operation in the event of a power failure.

Tri-Voltage operation allows the Overhead Environmental Cabinet to operate from 12 volt vehicle power as well as 120 and 240 volt AC shore power.

A built-in power distribution system switches automatically to the appropriate power source. With average long term current draw below 1.5 amps, the system can operate continually on battery power for over 24 hours with plenty of reserve for starting the vehicle. When AC shore power is available, the E-Cab will automatically switch over preventing any battery drain.

The Hoseline Overhead Environmental Cabinet is constructed for long life and high reliability even under the difficult operating conditions found in the emergency vehicle environment.

The refrigeration system features an extremely efficient and reliable hermetically sealed compressor with brushless DC variable speed drive for long life and quiet operation. The air circulation fans are also of the brushless design featuring ball bearing construction.

With no filters to plug up or clean and the built in automatic defrost system and easy clean interior, the Overhead Environmental Cabinet is virtually maintenance free.



### SPECIFICATIONS:

|                   |  |
|-------------------|--|
| Operating Voltage | 11.6 to 15.0 Volts DC Standard plus<br>100-240 Volts AC, 50-60 Hz with Tri-Voltage Option.   |
| Operating Current | 3 Amps @ 12 Volts with Compressor Running<br>Long term average approx. 1.2 Amps @ 12 Volts with<br>interior temp 40°F and exterior temp of 80°F<br>Note: Average current draw is a function of set point<br>temperature and outside temperature. |
| System            | Electronic control system with auto power transfer.<br>Hermetically sealed variable speed compressor<br>and 50 watt internal heater. Brushless D.C. fan.   |
| Control Panel     | Control panel comes with 5 feet of wire.<br>Can be extended up to 20' with ordinary<br>3 conductor thermostat wire.  |
| Set Point Range   | 35° to 80° F   |
| Weigth (approx.)  | 32 lbs   |
| Inside Dimensions | 20.5"W x 7.5"H x 7.5"D (Less Evaporator)   |

### DIMENSIONS: OVERHEAD CABINET

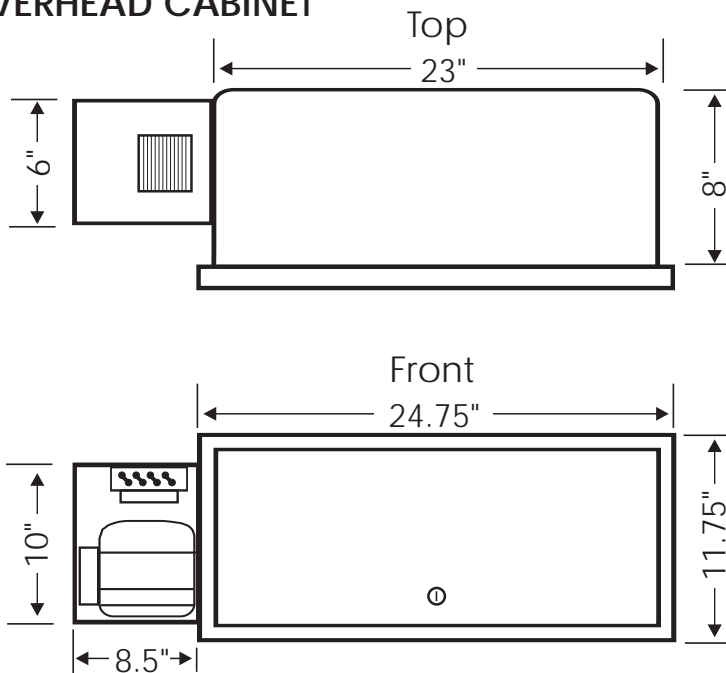

### DIMENSIONS: CONTROL PANEL

